

SAFETY IN EASY OPEN ENDS

A Retrospective on Product Evolvment in a Consumer-Oriented Society

By John Morrison, Automated Container Corporation.



AUTOMATED CONTAINER COMPANY

3450 W. Central Avenue, Suite 332
Toledo, Ohio 43606
Phone: (419) 536-8393
Facsimile: (419) 536-9686
E-mail: EZOBOB@accesstoledo.com
Web: www.automatedcontainer.com

Reprinted from

THE CANMAKER

JANUARY 1991

Sayers Publishing Group Ltd,
Durand House,
Manor Royal, Crawley,
West Sussex RH10 9PY,
United Kingdom.

Tel: 44 1293 435100. Fax: 44 1293 619988.
E-mail: canmaker@sayers-publishing.com

Safety in Easy Open Ends:

A Retrospective on Product Evolvement in a Consumer-Oriented Society

By John Morrison, Automated Container Corporation.

The first easy open can end was developed and test marketed - on Iron City beer - in October 1962. Safety was not a concern since the opening was small and designed only to pour the liquid contents.

Still, in November 1962, some beer drinker, drinking directly from a can, probably suffered a cut lip or tongue. Ever since that first "pop-tip" was developed, there has been a constant effort to improve the safety of easy-open ends. This article reviews the course those developments have taken.

Tab Safety

The flat tab first used evolved into a hemmed tab to reduce cuts and then into a ring tab to make opening the can easier and safer still. Ultimately, the "stay-on tab" was developed in response to both the problems of litter and safety.

Full panel Removable Ends

In the mid-sixties, innovative marketers began to see the potential for an easy-open end for snack food products if the end could be completely removed by pulling the tab. First, the beverage can was adapted with score lines modified so a spiral resulted which removed the entire centre panel.

The first such end, developed by Continental Can Co. in 1963, was of 211 diameter and it was used for frozen citrus. They used the beer can end — 211 was the standard then, remember? — and changed from the key hole opening (figure 1) to a spiral opening (figure 2)

Fig 1

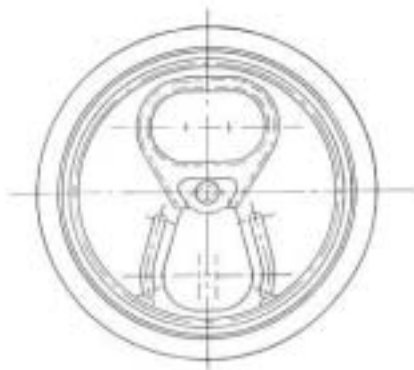

Fig 2

extending from the centre rivet in spiral shape to the periphery of the centre panel. What the user pulled away from the can was "a thousand razor blades." A few people were tempted to grab the long spiral to pull it away from the can, but wound up very quickly with cuts on many fingers. Surprisingly, this type of end is still in use in France on some paté cans illustrating the indifference to safety which still exists among many European canmakers and packers today.

First Indication of Need for Safety

Next, the beverage can end was modified by moving the rivet and tab to the can edge and providing a simple

Fig 3

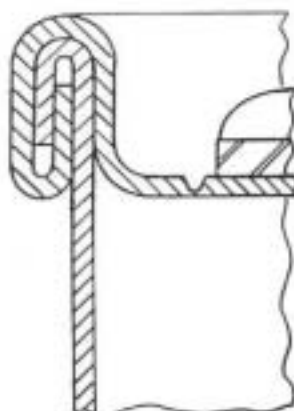

circular score (figure 3). This eliminated the many jagged edges on the spiral but still left dangerously sharp edges on the can rim and the circular centre panel. Particularly in larger sizes like 401 diameter (99mm), consumers cut themselves frequently on the sharp-edged can rim, reaching into the can for a dry product like peanuts or snack food.

These experiences convinced can makers, packers and the makers of easy open ends that improving the cut resistance of this end had to involve two separate efforts — protecting the rim side of the score line (or what remains on the can) and protecting the sharp edge on the removed centre panel.

Rim Protection

The first response to eliminating the rim side hazard is still used today — the introduction of a "guard bead" on the steel can body underneath the end (figure 4). A similar approach was taken by manufacturers of drawn and redrawn aluminium cans like United Can Co., but in this case a stepped shoulder was put on the can body (figure 5).

Fig 4

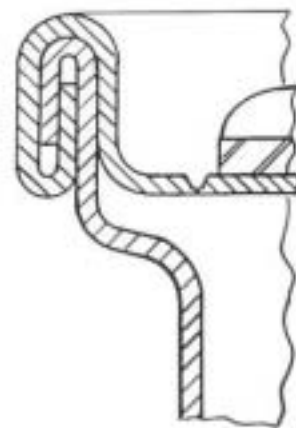
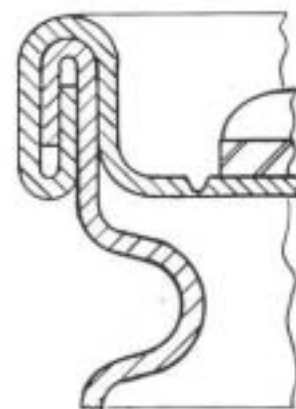

Fig 5



Both the guard bead and the stepped shoulder prevented, at least, any very deep cut, although the fact that the score line was on top of the safety feature still allowed some abrasion or slight nicking of the fingers.

An interesting approach to providing safety was taken by some small Japanese canmakers. They seamed a plastic ring between the can end and the can body. While this was effective, it was also a very expensive and clumsy technique.

In 1969, Owens-Illinois, Inc. developed an end with folded metal on the rim, called SAFERIM. The fold covered the score line (figure 6) and ensured the end passed the "pencil test" that is, when a yellow wooden pencil is run around the interior of a can with a SAFERIM top, the paint will not be scratched, as it would be in most of the other designs.

Fig 6

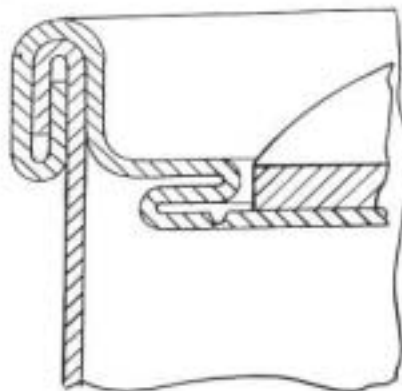

The SAFERIM design also had the benefit of allowing safety protection on cans which could not be guard beaded — like very lightweight steel cans or composite cans. In addition, the fact that the seaming chuck sits on top of the rim fold (figure 7) means that a standard chuck can be used with this end. In fact, many canmakers run identical seamer settings and tooling for plain steel and easy open SAFERIM ends.

Fig 7

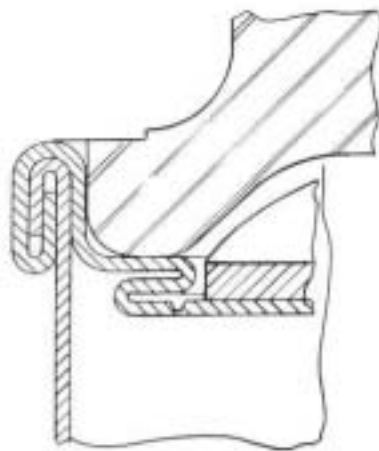

Other attempts at providing safety on the rim side of the end involved thick organic coatings. A number of companies (like Sonoco Products and Boise Cascade) chose to apply a hot melt coating on top of the score line (figure 8). American Can Co developed a plastisol coating applied on the inside of the end (figure 9).

Fig 8

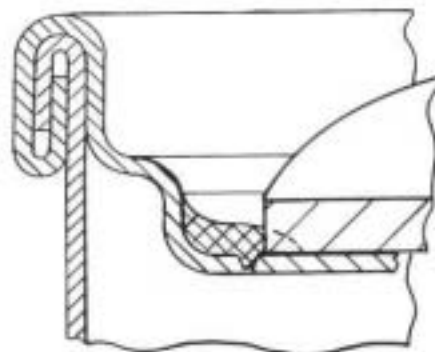
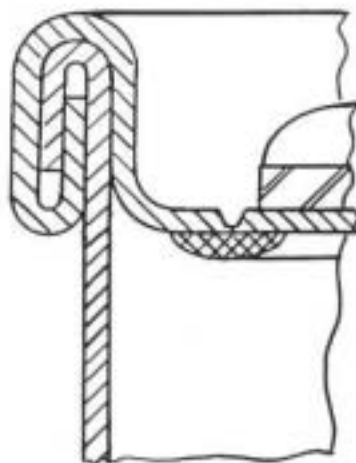

Fig 9



The Sonoco hot melt end, now known as Safety Shield, has endured to this day. The plastisol coated end proved difficult to control in production and does not have much of a market any longer.

Perhaps the latest rim protection method is the one commercialized by Continental Can Co. for infant formula cans — the "collapsed guard bead" (figure 10). This allowed for better protection than the standard guard bead but still, of course, provides no centre panel protection.

Centre Panel Protection

At the same time that efforts were being made to provide rim protection for full panel removal ends, there were strenuous efforts to provide centre panel

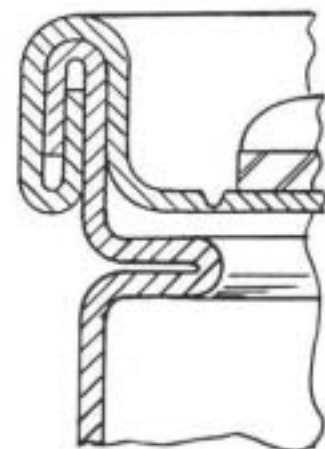
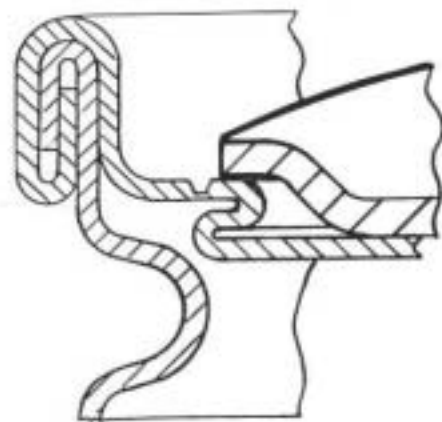

Fig 10

protection. There was one overriding motivation for this safety protection — the development of unit servings of puddings in about 1972. This seemed like a perfect product and was brought forth with great fanfare by a number of packers. When, however, a number of school children licked pudding off the unprotected centre panel, and cut their tongues, the negative publicity was so great that the product was withdrawn from the market immediately. Several can companies (Western Can and Central States Can, among others) started a crash course in providing centre panel protection and this developed into what is now known as triplefold (figure 11).

Fig 11



Double Protection

In the early 1970's two companies, Owens-Illinois and Continental Can, put the two developments together and made ends with both centre panel protection and rim side protection. Continental Can called its end "Tara Tara," while Owens-Illinois called its version "DOUBLESAFE" (figure 12). Because there were differences in the way the folds were created, the two

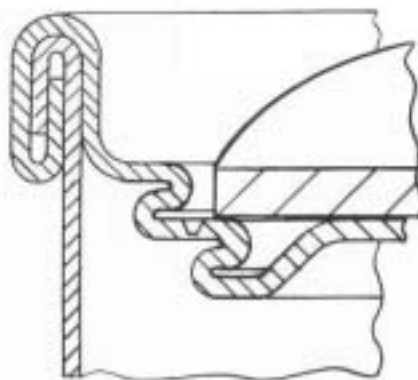

Fig 12

companies, both of whom had their own patents, ultimately decided to live and let live in the market place. Continental's end seems to be getting less and less market exposure — due in part to Continental's financial restructuring. The Owens-Illinois DOUBLESAFE end (now made by Automated Container Corporation of Orlando, Florida) is constantly expanding its uses. DOUBLESAFE provides protecting folds on both the rim and panel, for the ultimate in consumer safety.

Among other well-known brand names now using DOUBLESAFE are Anheuser-Busch's Eagle Snacks' honey roasted nuts; Kraft Inc, whipped cream cheese, Mauna Loa macadamia nuts, and Sunsweet stewed prunes. In addition, the Japanese use many of these ends for some of the more expensive brands of Nori — dried seaweed, an expensive gift item in Japan.

Marketing Effects

These developments, primarily centred in the United States, have occurred because there was customer demand for safety protection. The potential for litigation was, of course, a motivating factor, as was the similar but less likely potential of government regulation. Neither litigation nor regulation was necessary because marketers found themselves losing not just market share, but entire markets, because of the lack of appropriate cut protection.

There are many canned foods in the United States not found elsewhere in the world because of US marketers insistence on having a safe product. Without appropriate can end safety, puddings in cans didn't sell, snack foods in cans didn't sell and canned peanuts didn't sell. When the appropriate safety feature was provided in the can ends, the respective markets blossomed.

Easy Open Safety Today

The lesson concerning the need for safety was learned early on in both the

United States and Japan. Up to nine out of ten cans with easy open ends sold in these markets have rim or rim and panel protection, depending on the product packed.

The need for safety still seems to have eluded most Europeans. While in France there are many retail products using easy open ends, these tend to be processed foods where is little temptation to lift the product out of the can with ones fingers. Carnaud (now CMB Packaging) and Cebal both make many full panel removable ends, but provide very few with either rim protection or centre panel protection, and the market has accepted these products with no safety protection to a degree that would be remarkable in the US and Japan.

Automated Container's European Effort

At Automated Container, we believe that Europe will soon experience the same consumer demand for safety that drove safety protected ends to dominance in the US and Japan. To that end, we're making a concerted effort to educate Europe on the need for safety.

Automated Container Corporation is now represented in Europe by Parliament International of Great Britain. Technical assistance is provided in selecting the proper end for any application. Sample quantities for test runs are provided at no cost.

We are organized to ship economically to Europe and have developed systems to handle currency and letter of credit situations. We really believe European canmakers and packers need safety protected easy open ends. Finally, we intend to be in a position to provide them.

The Author

John Morrison is the President of Automated Container Sales Corporation, exclusive sales representative of Automated Container Corporation, the leading independent producer and marketer of easy open ends. He has been a part of the can industry for over thirty years, first at Container Corporation of America, then at Owens-Illinois and recently at Automated Container. John has personally watched and been a part of every step in the evolution of safety in easy open ends.

Contact: John Morrison, President, Automated Container Corporation, 3450 Central Avenue, Toledo, Ohio 43606, USA. Tel: (419) 536-8393. Fax: (419) 536-9686.

Contact: David Munk, Director, Parliament International Ltd., Sheridan House, 17, St. Ann's Road, Harrow, Middlesex, HA1 1JU, UK. Tel: 081-861 3505 Tx: 894281 Fax: 081 861 2025.

AUTOMATED CONTAINER COMPANY
 3450 W. Central Avenue, Suite 332, Toledo, Ohio 43606
 Phone: (419) 536-8393 • Facsimile: (419) 536-9686
 E-mail: EZOB@access.toledo.com
 Web: www.automatedcontainer.com

